

## ecostore Premium 2 Door Digital Freezer, 1430lt (-22/-15) - R290

ITEM # \_\_\_\_\_

MODEL # \_\_\_\_\_

NAME # \_\_\_\_\_

SIS # \_\_\_\_\_

AIA # \_\_\_\_\_

**727323 (ESP142FFC)**

 Eco Store Premium Freezer -  
 1430 lt 2 Door (-22/-15) -  
 R290 - 230 V/1N/50Hz

### Short Form Specification

**Item No.** \_\_\_\_\_

Two full door freezer entirely constructed in 304 AISI stainless steel with bottom panel in anti-corrosive material. Large digital white-digit display with cabinet temperature display and setting. HACCP-compliant control with alarms and history. Frost Watch Control to defrost only when required with automatic evaporation of defrost water. Optiflow: back to front forced air flow and removable air conveyors provides even temperature distribution and fast cooling in any conditions. Fitted with 75 mm-thick cyclopentane insulating foam. Door features lock and door microswitch to switch off the fan when the door is opened. Hidden evaporator to guarantee higher storage capacity and less corrosion problems. Built-in refrigeration unit; ventilated operation; Internal LED light. CFC and HCFC free. R290 gas in refrigeration circuit. Supplied with n. 8x2/1GN Rilsan coated grids and n. 8 sets of 2 stainless steel grid runners. Prearranged to fit RS485 port to facilitate connection to a remote computer and integrated HACCP systems.

### Main Features

- Large storage area suitable to contain 2/1 GN grids or shelves on anti-tilt runners.
- Optiflow: back to front forced air flow and removable air conveyors provide even temperature distribution and fast cooling in any conditions.
- Cabinet fitted with up to 75 mm thickness of cyclopentane insulation for best insulating performance with 100% environmental protection (thermal conductivity: 0,020 W/m\*K).
- 60 mm-thick insulation covering the evaporator can be easily removed with a single operation.
- Prearranged to fit RS485 port to facilitate connection to a remote computer and integrated HACCP systems.
- Rilsan coated grids for improved protection.
- Large digital white-digit display with cabinet temperature display and setting, activation of turbo frost cycle (to rapidly cool warm loads) and possibility to activate manually the defrost cycle.
- Connectivity ready for real time access to connected appliances from remote and data monitoring (requires optional accessory).
- Internal structure with 44 charging positions available to host grids, ensuring higher net capacity and a greater storage space.
- Possibility to select 3 different levels of humidity according with the type of food stored inside.
- Electrolux Professional Fridge Control APP make the life easier for our customers (available from April 2024):
  - Monitor safety of preservation process thanks to HACCP data & alarms for precise control
  - Save time and easy data management having the possibility to send the HACCP information in excel format directly to e-mail address
  - Quick operations: set the cabinet temperature/turbocooling and set date/hour

### Construction

- Constructed from the highest quality AISI 304 Stainless steel.
- Interior base with rounded corners, pressed from a single sheet.
- The rounded internal corners, the easily removable runners, grids and air conveyors allow for ease of cleaning and high hygiene standards.
- Stainless steel runners and supports easily disassembled.
- Anti-corrosion bottom avoids any damage that may be caused to the cabinet by aggressive detergents employed to clean the floors.
- Easy access to the main components for maintenance.
- Lockable door.

### Included Accessories

- 8 of 2/1GN grey rilsan grid with 2 runners PNC 881020

**APPROVAL:** \_\_\_\_\_

Front

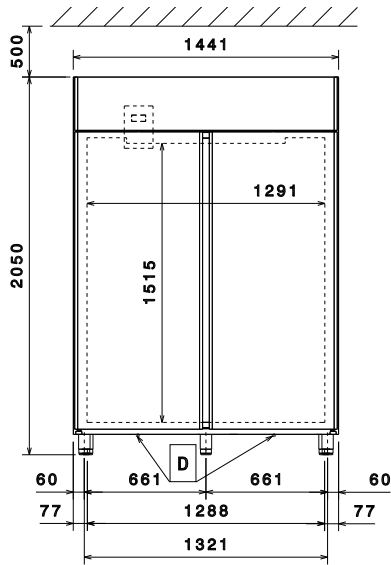

Side

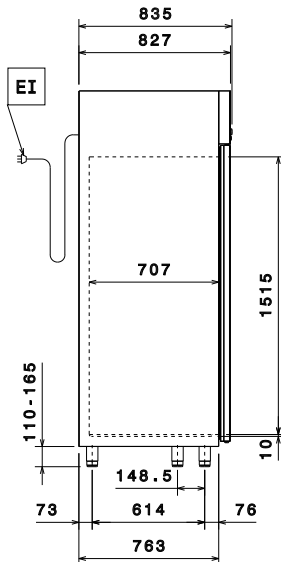

EI = Electrical inlet (power)

Top

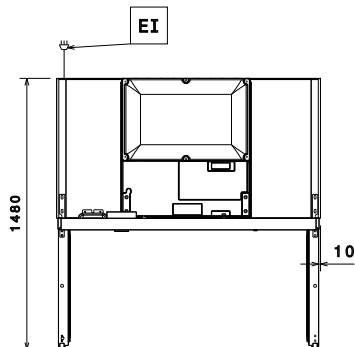

### Electric

Supply voltage:	727323 (ESP142FFC)	220-240 V/1 ph/50 Hz
Electrical power max.:		0.7 kW

### Key Information:

Gross capacity:	1430 lt
Net Volume:	1135 lt
Door hinges:	1 Left+1 Right
External dimensions, Width:	1441 mm
External dimensions, Depth:	835 mm
External dimensions, Depth with Doors Open:	1480 mm
External dimensions, Height:	2050 mm
Number and type of doors:	2 Full
Number and type of grids (included):	8 - GN 2/1
Type of external material:	304 AISI
Type of internal material:	304 AISI
Internal panels material:	304 AISI
Number of positions & pitch:	44; 30 mm

### Refrigeration Data

Control type:	Digital
Refrigeration power at evaporation temperature:	-30 °C
Operating temperature min.:	-22 °C
Operating temperature max.:	-15 °C
Operating mode:	Ventilated

### Product Information (EU Regulation 2015/1094)

Type of model (EU Reg. 2015/1094):	vertical frozen
------------------------------------	-----------------

### ISO Certificates

ISO Standards:	ISO 9001; ISO 14001; ISO 45001; ISO 50001
----------------	---

### Sustainability

Energy Class (EU Reg. 2015/1094):	D
Yearly and daily energy consumption (EU Reg. 2015/1094):	4314kWh/year - 12kWh/24h
Climate class (EU Reg. 2015/1094):	Heavy Duty (5)
Energy Efficiency Index-EEI (EU Reg. 2015/1094):	61,05
Refrigerant type:	R290
GWP Index:	3
Refrigeration power:	833 W



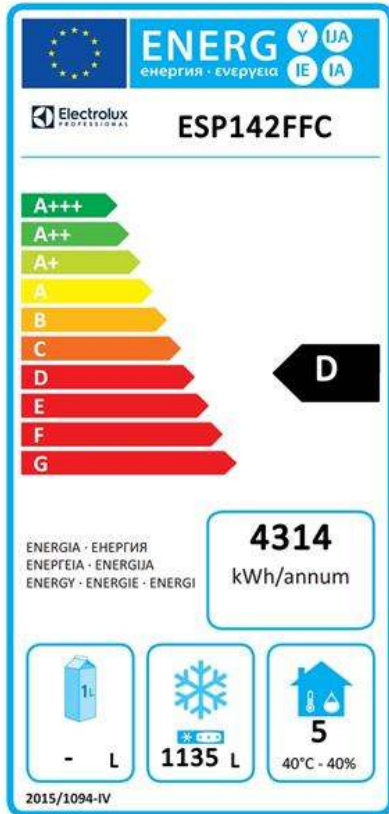

### EU energy labelling from 1st July 2016

The European energy labelling scheme for professional refrigerators and freezers is based on requirements setting Minimum Energy Performance standards for commercial refrigeration cabinets sold within the EU.

These requirements are designed to drive energy efficiency and environmentally friendly approach for professionals. The European energy labelling scheme will apply to all manufacturers and importers who sell and market products within the EU and it is mandatory across Europe. Important: all products which consume energy above the minimum level will not be able to be sold within the EU from 1 July 2016.

SI 2020 No. 1528.

Important: all products which consume energy above the minimum level will not be able to be sold within the EU from 1 July 2016.

